



SA106C-XXBS

www.sac-ontop.com.tw

6W Switching Adapter

Input

Rated Voltage	100 - 240 VAC
Max. Voltage	90 - 264 VAC
Line Frequency	47 - 63 Hz
Current	250mA at 100-240VAC
Configuration	British -2PIN

Output

Model Name	Voltage	Current	Watt	Efficiency
SA106C-05BS	5V	1.2A	6W	65%
SA106C-09BS	9V	0.7A	6.3W	70%
SA106C-12BS	12V	0.5A	6W	70%
Line Regulation	Less than $\pm 2\%$			
Load Regulation	Less than $\pm 5\%$			
Protections	OCP, OVP & SCP			
Ripple & Noise	$\leq 100\text{mVp-p}$, (For 5V, 9V models) $\leq 120\text{mVp-p}$, (For 12V model)			

Environment

Operating Temp.	0°C - 40°C
Storage Temp.	-20°C - 80°C
Humidity	10% - 90% (Non-condensing)
RoHS & WEEE	Standard

Reliability

MTBF	50,000 hrs (by MIL-217 Standard)
Safety	ITE: TUV/GS, CB, CE

Others

Package	100 pcs/box
Min. Order	1K pcs/lot
Warranty	1 year

Electrical

Topology	Switching Mode
Hi-Pot	3000 Vac/1sec @ 5mA (primary - secondary)
Leakage Current	$\leq 0.25\text{mA}$, at 264VAC/50Hz
Hold Up Time	≥ 6 mSec
Standby Power	≤ 0.3 Watt
EMI	Complies with EMI directive
ErP Requirement	Efficiency Level : Stage 2 (9V & 12V only comply with ErP Stage 1)

Mechanical

Case Size	64L x 45W x 31H mm
Case Material	Black, 94V-1 or equivalent
Weight	95 ± 5 g
DC Cord	4.92ft

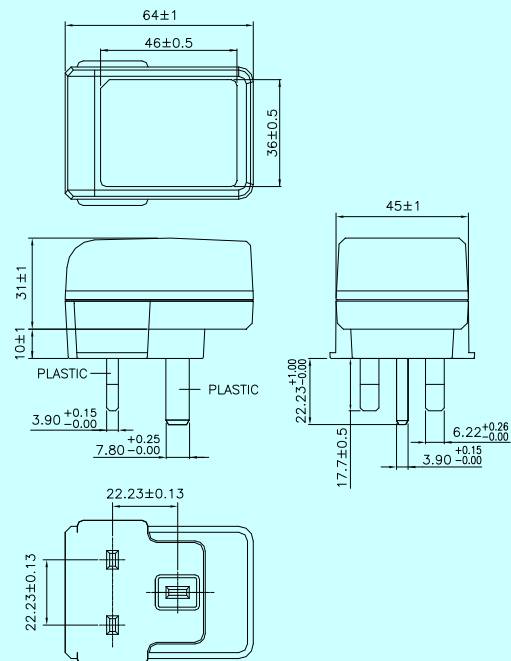

For reference only. For details please contact your local sales representative